

Immersion pumps

Type IMM 90 - 100



Usages:

The pumps are suitable to transfer liquids containing impurities measuring up to 3-4 mm. The hydraulic components, namely the cast iron impeller and scroll and the steel pump body allow the pumps to be used with water, emulsions and oily substances in general with a maximum viscosity of 3 Engler (21 CST).

The temperature of the liquid must not exceed 90 °C.

They are usually used with:

- Machine tools
- Glass processing machines
- Surface treatment systems
- Filtration systems
- Painting cabins

They should usually be installed on a tank, with a capacity in proportion to the flow rate, at about 7-8 cm. from the bottom. It is important to check that the maximum level of the liquid in the tank always remains 5 - 6 cm. lower than the flange (see figure).

In cases where the liquid is particularly dirty, the user is recommended to construct the tank in compartments to allow the dirt to deposit before it is stirred up by the pump.

For other usages you are advised to consult our technical office.

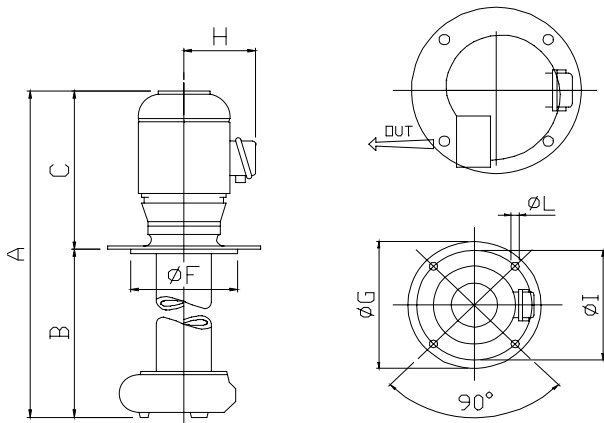

TYPE	A	B	Kg.	C	mm 345
	mm	mm		ØD	2 "
IMM 90 A	695	350	42,00	ØE	mm 235
	795	450	48,10	ØF	mm 240
	945	600	48,80	ØG	mm 300
	1145	800	50,00	H	mm 130
IMM 90 B	695	350	49,00	ØI	mm 270
	795	450	49,60	ØL	mm 13 - N. 4
	945	600	50,00		
	1145	800	51,50		
IMM 100 B	730	350	53,00	C	mm 380
	830	450	53,60	ØD	2- 1/2 "
	980	600	54,30	H	mm 145
	1180	800	55,50	Ø E-F-G-I-L= IMM 90	

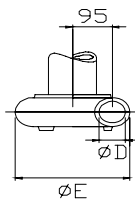

Electrical features

Type	KW. Input	Hz. 50		Hz. 60			
		230/400	254-290/440-500	230/400	208-230/440-460	254-277/440-480	318-346/550-600
IMM 90 A	1,85	8,6/5,0	6,5/3,7	10,2/6,0	9,0/5,2	8,6/5	6,8/3,9
IMM 90 B	2,80	10,8/6,2	8,3/4,8	13,0/7,5	11/6,4	10,8/6,2	8,5/4,9
IMM 100 B	4,80	14,9/8,6	11,5/6,6	17,6/10,1	15,2/8,8	14/9/8,6	11,8/6,8

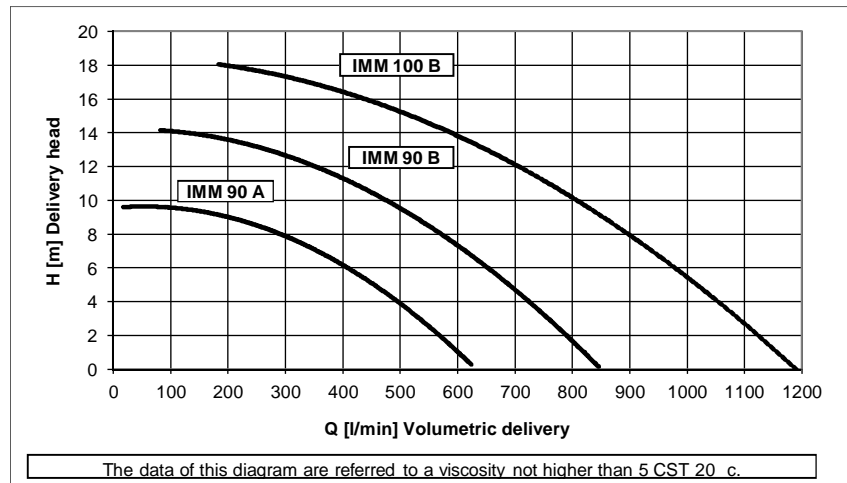
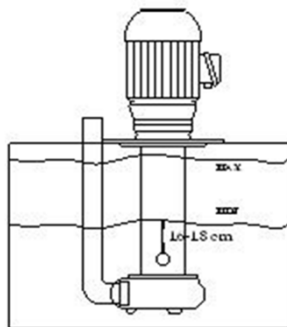

Immersion pumps

Type IMM 90 - 100

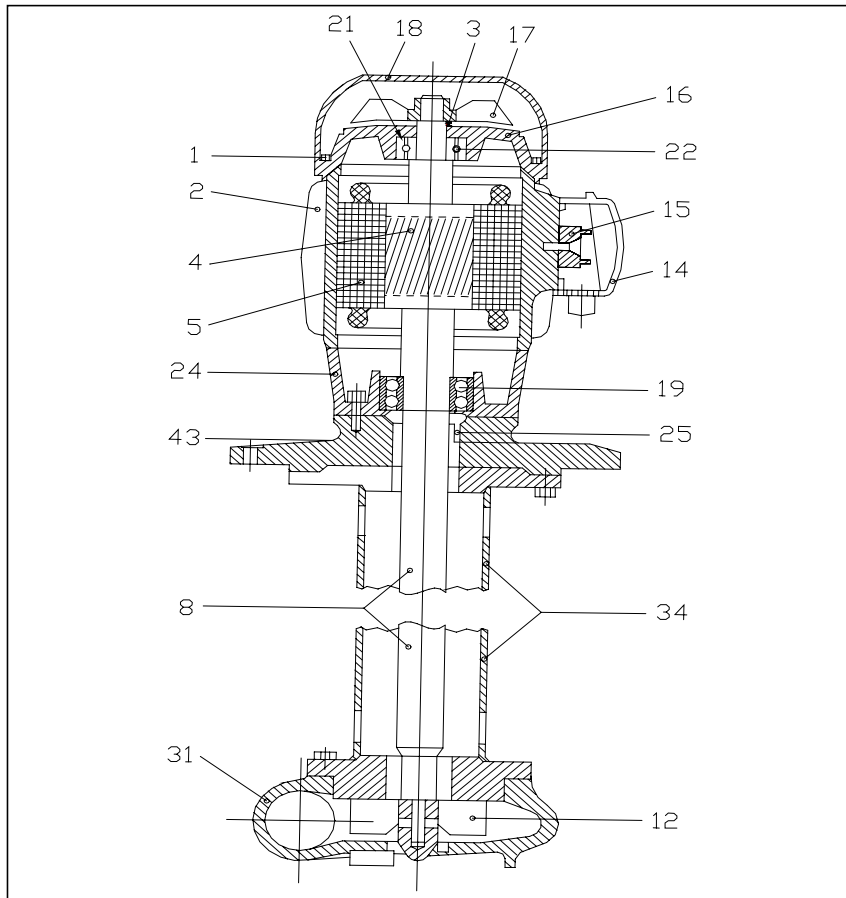

Materials

Components

1	Rod
2	Frame
3	V-Ring
4	Rotor
5	Stator
8	Shaft
12	Impeller
14	Terminal box
15	Terminal clock
16	Non-drive end shield
17	Fan
18	Fan coverù
19	Bearing
21	Spring ring
22	Bearing
24	Drive end shield
25	Sealing ring
31	House impeller
34	Tube
43	Support flange

IMM 90 A

Steel
Aluminium
NBR ø 25
Steel
Cast iron G20
Nylon
mm. 50x32 6P
Aluminium
Nylon
Nylon***
3207 ATN9 2RS
ø 52
6205 ZZ
Cast iron G20
NBR 35X62X10
Cast iron G20
Steel
Cast iron G20

IMM 90 B

Steel
Aluminium
NBR ø 25
Steel
Cast iron G20
Nylon
mm. 50x32 6P
Aluminium
Nylon
Nylon***
3207 ATN9 2RS
ø 52
6205 ZZ
Cast iron G20
NBR 35X62X10
Cast iron G20
Steel
Cast iron G20

IMM 100 B

Steel
Aluminium
NBR ø 30
Steel
Cast iron G20
Nylon
mm. 50x32 6P
Aluminium
Nylon
Nylon***
3207 ATN9 2RS
ø 62
6206 ZZ
Cast iron G20
NBR 35X62X10
Cast iron G20
Steel
Cast iron G20

On request

Sheet